

HALLCOTM INDUSTRIES, INC.

Owner's Manual:

4000 SERIES LIVE FLOORTM CONVEYING SYSTEMS One-Way (4100) and Two-Way (4200)

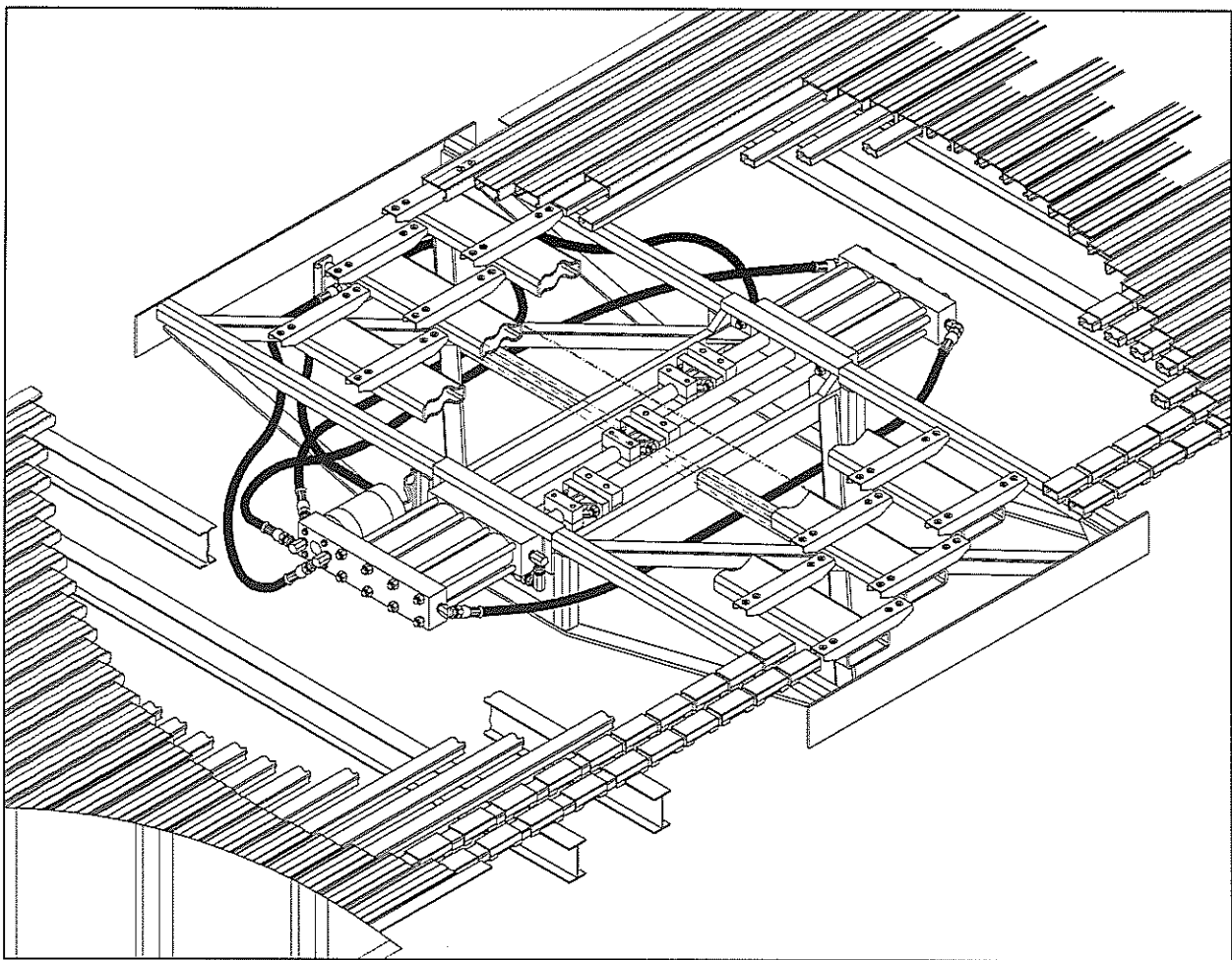

Wilkins Industries, Inc.
1-800-833-6045
Parts: Ryan Snyder
email: ryans@wilkins-ind.com

**-FOR YOUR SAFETY-
Read Carefully Before Operating Floor**

This floor contains moving components and carries large loads which are capable of causing injury or death, if the following precautions are not followed carefully:

- Lock out or isolate the power source from floor while performing installation, inspections, cleaning, or maintenance.
- Keep all body parts clear of the floor mechanisms while the floor is operating.
- DO NOT operate floor while a person is on the floor.
- DO NOT stand at the opening of the container while the floor is unloading or in the way of the unloading doors which may be pushed by the moving load.
- Use caution when opening container doors even when floor is not operating. The load may have shifted against the door in transit causing the door to open rapidly when unlatched.
- DO NOT operate the floor in the unloading direction with the unloading door(s) closed. DO NOT shift the load material against the forward wall with the floor. The installing activity must provide a means for the operator to visually monitor the load when shifting it forward. This floor is capable of causing serious damage to the box structure and may pose a safety hazard, if the load is shifted against the rear or forward box structure.
- DO NOT operate floor above the maximum operating pressure specified in this manual.
- Observe Hallco safety sticker instructions.

TABLE OF CONTENTS

SAFETY	2
SAFETY & OPERATIONAL DECALS	3
HOW THEY WORK.....	4
FLOOR COMPONENTS	5-6
SPECIFICATIONS	7
THEORETICAL UNLOAD TIMES	7
HYDRAULIC REQUIREMENTS.....	8-9
OPERATING THE FLOOR.....	10-11
TROUBLESHOOTING	12
CLEANING	12
INSPECTIONS.....	13
REPAIRS	13-25
External Plumbing	14-15
Hydraulic Module Overhaul	16-20
Switching Rod Stops	21
Switching Valve Overhaul.....	22-23
Two-Way & One-Way Control Valve Overhaul	24-25
WARRANTY	26

SAFETY & OPERATIONAL DECALS

Prior to operating the LIVE FLOOR system check that the safety and operational decals are installed on the container. Refer to Figure 1 (this page).



Safety & Operational Decal Placement Guide For Hallco Live Floors®

99-4400

1 Qty 2

99-4806

2 Qty 2

99-4807

3 Qty 2

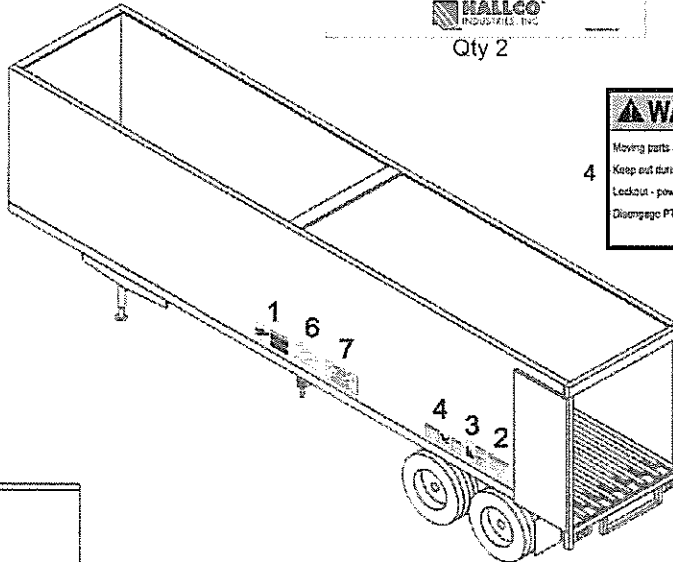

99-4408

4 Qty 3

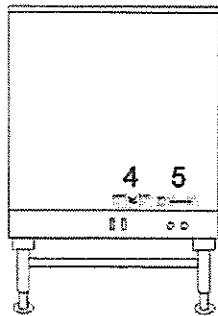

Trailer front

Rear decals should be applied so they are completely visible with the doors open

99-4399

5 Qty 1

99-4398

6 Qty 1

99-4401

7 Qty 1

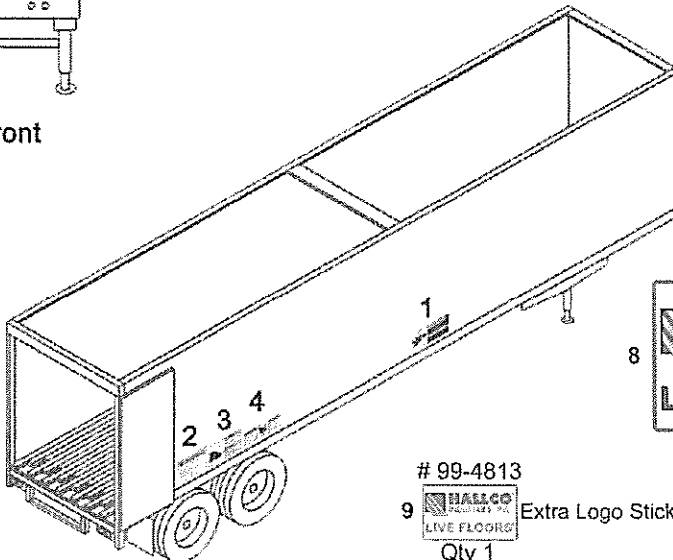

99-4809

8 Qty 1

Logo sticker should be placed on rear door.

99-4813

9 Extra Logo Sticker Qty 1

-Figure 1-

Safety & Operational Decal Placement Guide

HOW THEY WORK

1. All Slats Move Together Moving the Load With Them. →

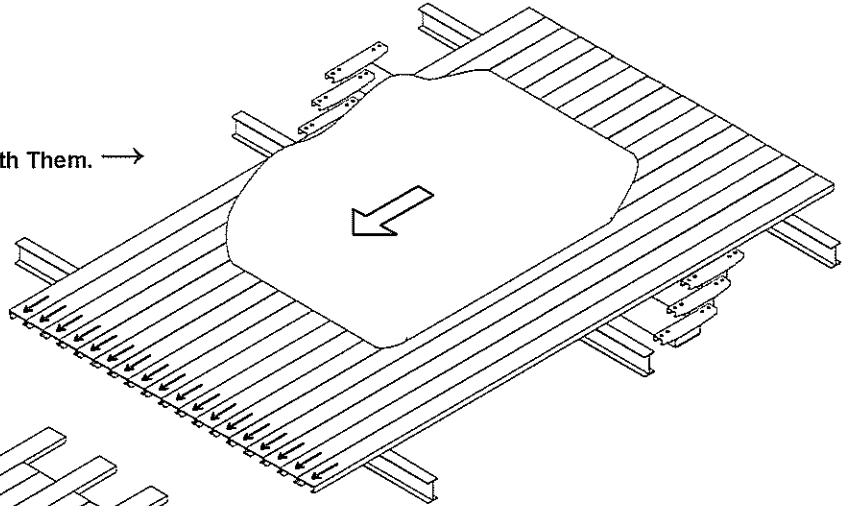

← 2. One-Third of the Slats Retract. Two-Thirds Hold the Load.

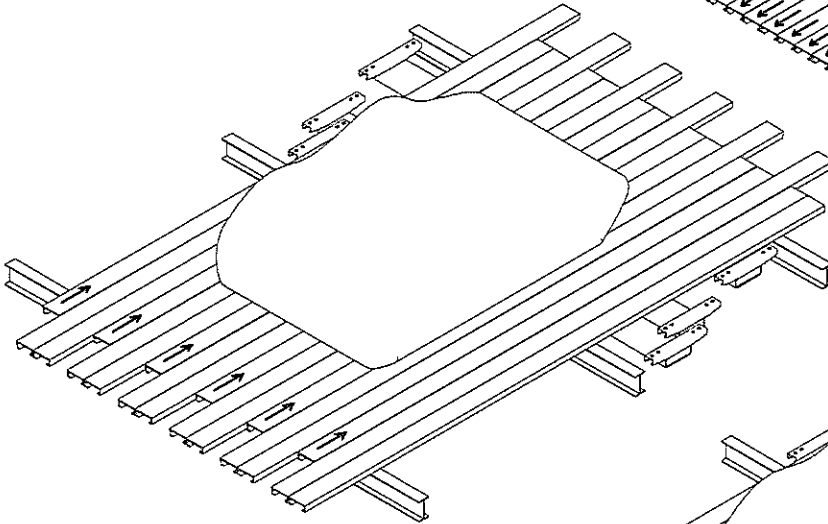

3. Next One-Third of the Slats Retract. Two-Thirds Hold the Load. →

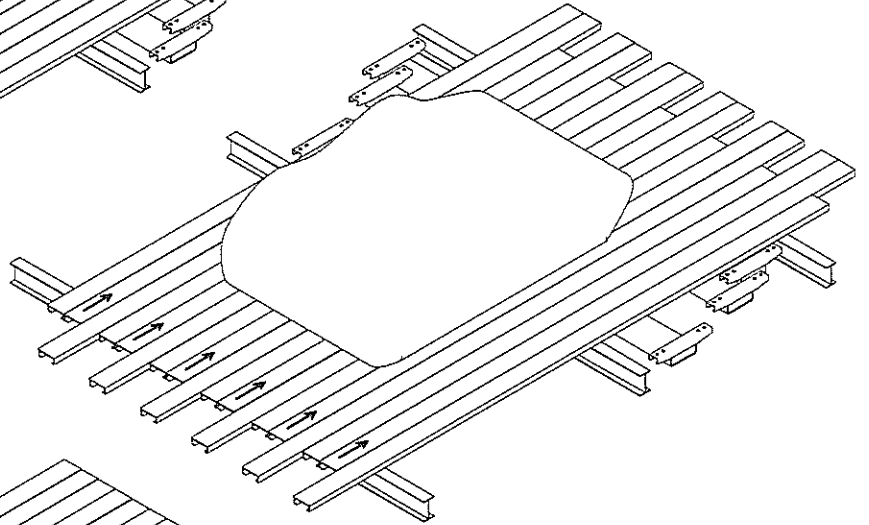

← 4. Last One-Third of the Slats Retract. Two-Thirds Hold the Load.

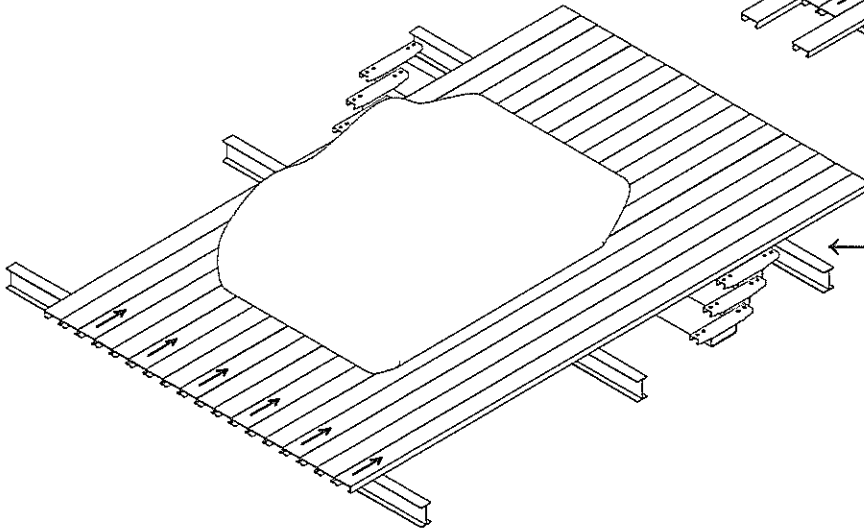

Cycle Repeats...

-Figure 2-
How They Work

FLOOR COMPONENTS

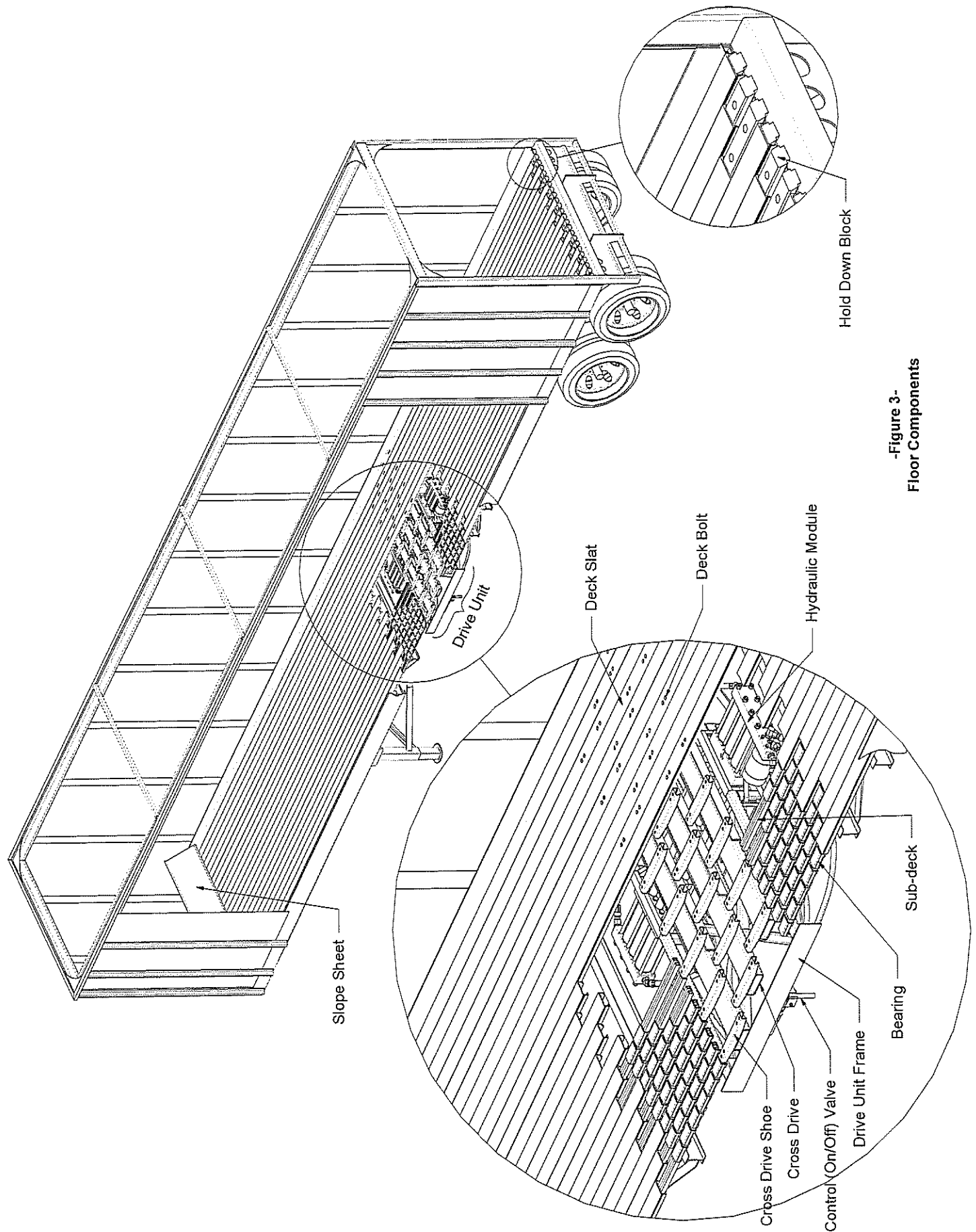

-Figure 3-
Floor Components

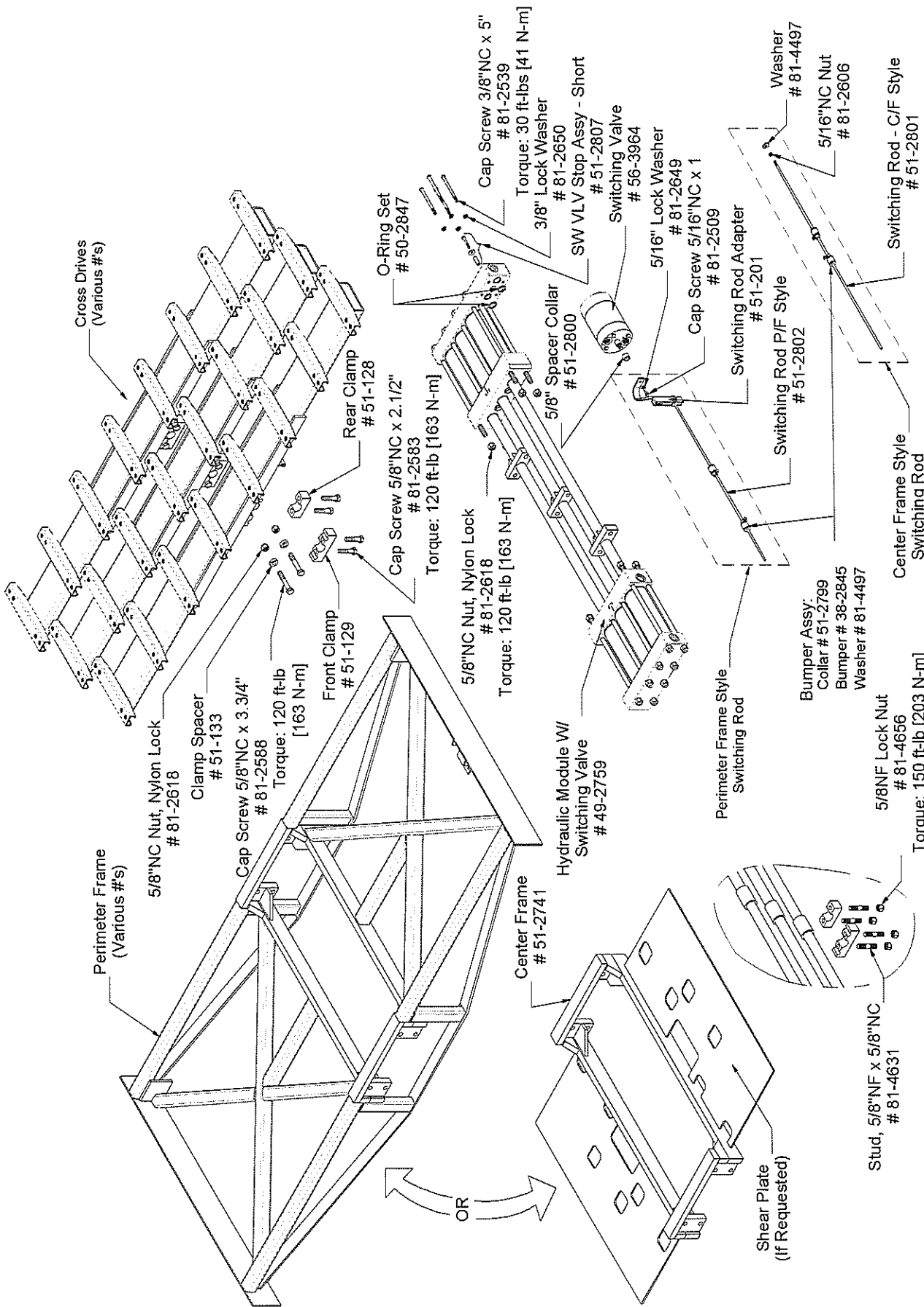

-Figure 4-
Drive Unit-Exploded View

SPECIFICATIONS

Hydraulic Module: 4100 (One-Way) or 4200 (Two-Way)

Maximum Hydraulic Pressure: 3000 psi [207 Bar]

Maximum Hydraulic Flow Rate: 30 gal/min [114 l/min]

Floor Stroke: 10 inches [254 mm]

Hydraulic Module Shaft Diameter: 1.5 inch [38.1 mm]

Hydraulic Module Cylinder Diameter: 3 inches [76.2 mm]

Load Capacity: 35 Ton [31 Tonne]

THEORETICAL UNLOAD TIMES

-Table 1- Theoretical Unload Times—45 ft. [14 m] Container			
Oil Flow (GPM [LPM])	Cycle Time (seconds)	Convey Speed (ft./min. [m/min.])	Unloading Time (minutes)
15 [57]	12.9	3.3 [1.01]	13.6
16 [61]	12.1	3.5 [1.08]	12.8
17 [64]	11.3	3.8 [1.14]	12.0
18 [68]	10.7	4.0 [1.21]	11.3
19 [72]	10.2	4.2 [1.28]	10.8
20 [76]	9.6	4.4 [1.34]	10.2
21 [79]	9.2	4.6 [1.41]	9.7
22 [83]	8.8	4.9 [1.48]	9.3
23 [87]	8.4	5.0 [1.55]	8.9
24 [91]	8.0	5.3 [1.61]	8.5
25 [95]	7.7	5.5 [1.68]	8.2
26 [98]	7.4	5.7 [1.75]	7.9
27 [102]	7.1	6.0 [1.81]	7.6
28 [106]	6.9	6.2 [1.88]	7.3
29 [110]	6.7	6.4 [1.95]	7.0
30 [114]	6.4	6.6 [2.01]	6.8

HYDRAULIC SYSTEM REQUIREMENTS

Hydraulic

Pump: This floor is rated to 3000 psi [207 Bar] operating pressure. Installing a pump which provides lower output pressure may result in poor operation. Maximum flow rate is 30 gallons [114 liters] per minute.

Hydraulic

Reservoir: 30 gallons [114 liters] minimum capacity. The hydraulic reservoir must have facilities to mount the relief valve and a return line filter. Both of these items must dump the oil into the reservoir below the low level line. Hallco suggests a down draft be installed in the reservoir on the return line to limit the turbulence. The pump supply oil should be taken from 1" to 2" [25 to 51 mm] above the bottom of the reservoir. This outlet should be screened or baffled to prevent whirlpool. The whirlpool could introduce air into the system. A sight gauge or other means of visually checking oil level should be installed.

Hydraulic

Oil: Select a petroleum or mineral base anti-wear (AW) hydraulic fluid in ISO viscosity grade 46 or 68. Most synthetic and vegetable based biodegradable hydraulic fluids are also compatible provided the moisture content in the fluid is kept below 1%. Hydraulic fluid temperatures must always be kept below 200° F (93° C).

Relief

Valve: The relief valve must be external, relieved directly to tank, and set at 3000 psi [207 Bar] maximum. The relief valve must be able to handle the maximum system flow rate.

Filler Cap: Filler cap must have a fill filter and a breather cap (unless already provided separately).

Hydraulic Plumbing:

Early systems were plumbed with 3/4" NPT fittings into the manifolds. Later system changed to 3/4" o-ring fittings (ORB). Do not install pipe thread fittings into o-ring style ports and vice versa.

1" [25 mm] size hydraulic hoses are recommended for the supply and return lines which connect to the switching valve ports labeled "P" for pressure and "T" for tank/return. See Figure 7 (page 11).

Quick

Connects: Mating quick connects must be of the same type and must be rated above the maximum system flow.

Filter:

A 25 micron (or finer) filter rated above the maximum flow rate of the system must be installed on the return line. A good filter is essential to assure clean oil for a long system life. For units where quick connects are frequently connected and disconnected (where contaminants may be introduced) a pressure line filter is recommended between the quick connect and the hydraulic module.

Pressure

Gage: 0 to 5000 PSI [0 to 350 Bar] range, glycerin filled.

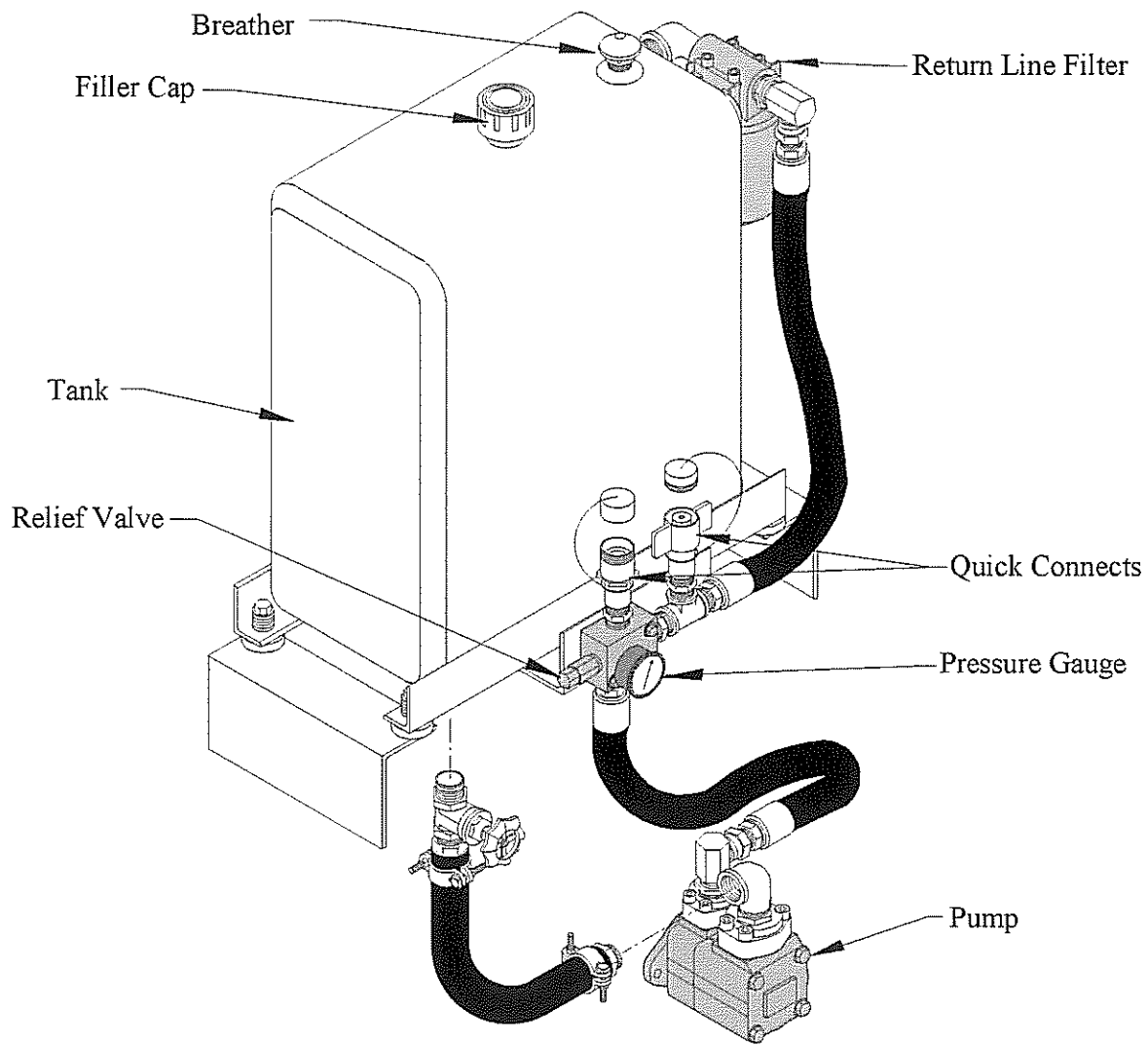

-Figure 5-
Example Hydraulic Supply System

OPERATING THE FLOOR

The hydraulic module which drives the deck slats is produced in two types, one-way and two-way. The one-way module is designed to move the load material in one direction only. The one-way module is controlled by a two-position valve, neutral and unload positions. The two-way module can move material in loading or the unloading directions. It is controlled by a three position valve (unload, neutral, load). Refer to Figure 6 (this page).

When unloading material, or when shifting the load material in the unloading direction, make sure the exit door is fully open. When shifting the material in the load direction, be sure you have a visual means of monitoring the position of the load. The load must not be shifted against the forward wall. If the load is conveyed against the wall structure by the floor, it will more than likely cause structural damage to the box and put the operator and/or bystanders at a safety risk.

NORMAL OPERATION IN UNLOAD MODE (One-Way & Two-Way Modules):

1. All deck slats move together towards the exit door.
2. First slat set (cross drive 1) moves away from the exit door.
3. Second slat set (cross drive 2) moves away from the exit door.
4. Third slat set (cross drive 3) moves away from the exit door.

Cycle repeats.

NORMAL OPERATION IN LOAD MODE (Two-Way Modules):

1. All deck slats move together away from the exit door.
2. Third slat set (cross drive 3) moves towards the exit door.
3. Second slat set (cross drive 2) moves towards the exit door.
4. First slat set (cross drive 1) moves towards the exit door.

Cycle repeats.

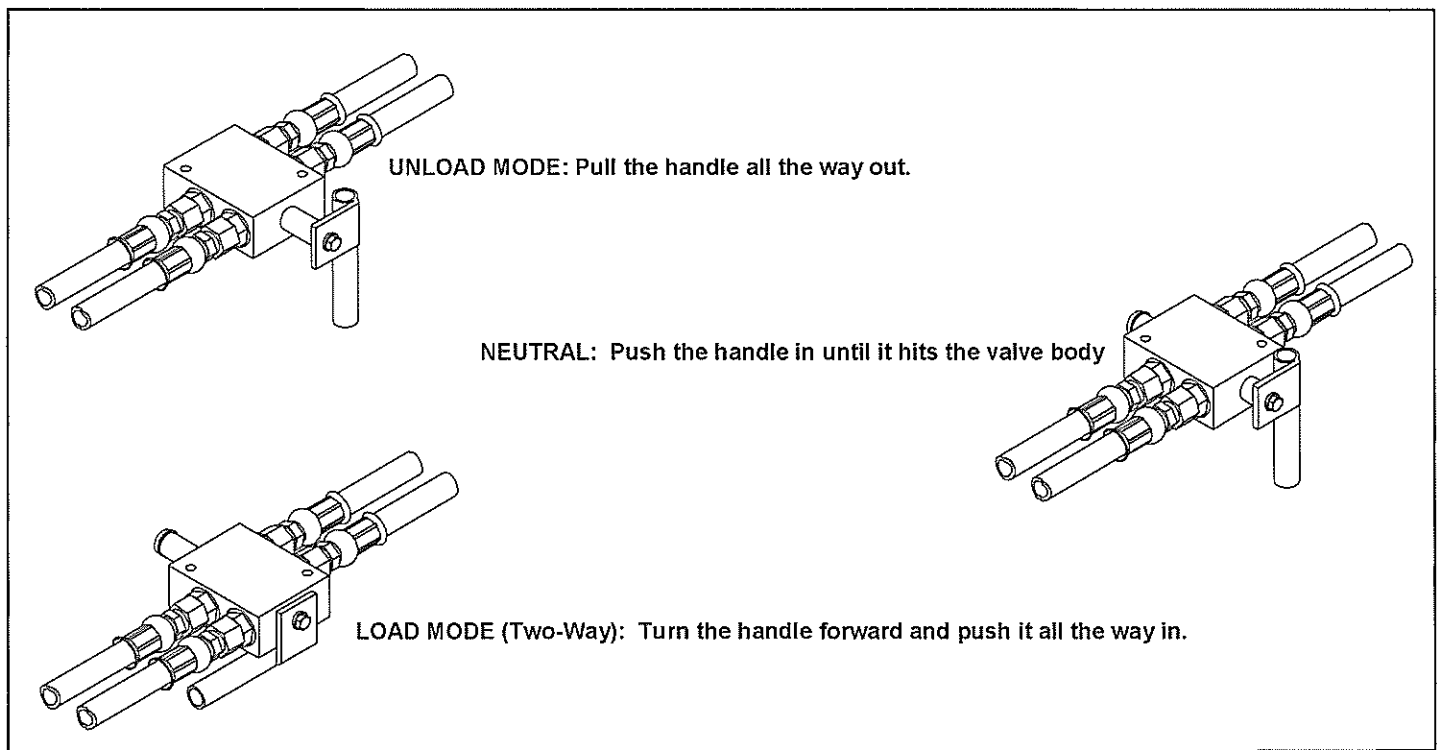

-Figure 6-
Control Valve Positions

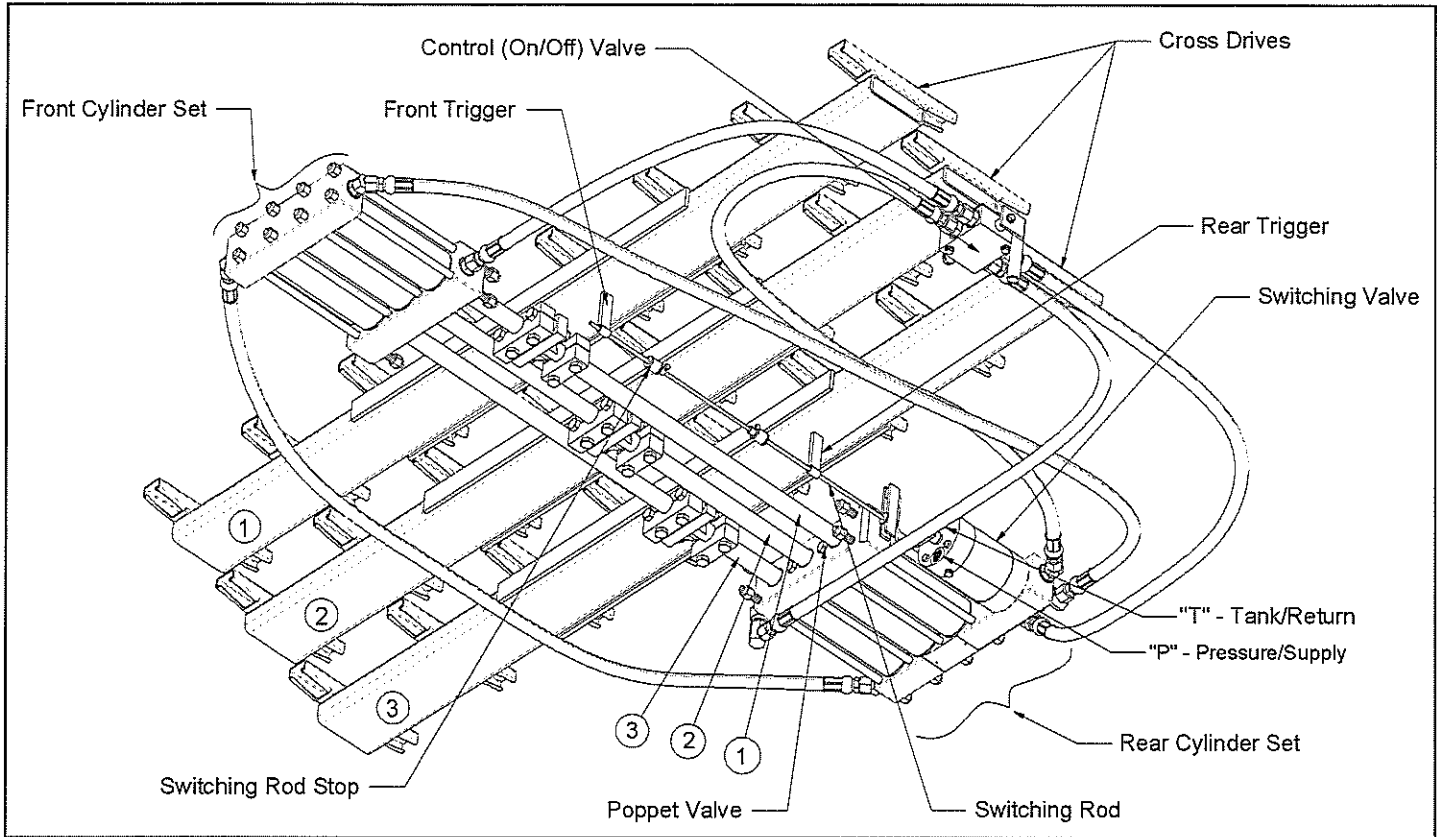

-Figure 7-
 Underside of Drive Unit

TROUBLESHOOTING

Experience has shown that most problems originate with the hydraulic supply system. If your floor is not functioning properly, first check for visible interference/damage of the floor structure or mechanisms, then check the hydraulic supply system.

Problem: Floor does not operate or operates slowly

- First Check:**
- (A) PTO. Is it fully engaged?
 - (B) OIL. Is the oil reservoir full?
 - (C) QUICK CONNECTS. Are they fully connected? Are they a matched set?
 - (D) PUMP. Is the pump operating? Does it deliver the specified flow rate and pressure?
 - (E) RELIEF VALVE. Is it set high enough (within specified limit)?
 - (F) PLUMBING. Is the entire system plumbed correctly?

If the problem persists...

Disconnect the pressure line from the hydraulic module. Attach a hydraulic pressure gage to the pressure line. Start up the hydraulic system (typically by engaging the PTO) and activate pressure to the pressure line. If the pressure gage shows sufficient pressure being supplied to the hydraulic module, then the hydraulic supply system is OK. If there is insufficient pressure being supplied to the hydraulic module, then the hydraulic supply system may need servicing.

Common hydraulic supply system problems are defective pump and defective relief valve. If the pump ONLY becomes hot, that is a clue to a bad pump. Another clue to a bad pump is having to rev up the engine to get enough pressure to operate the floor. If the relief valve ONLY becomes hot, that is a clue that the relief valve is defective or has debris holding it partially open.

If the hydraulic supply system checks out OK, but the floor still does not operate...

Check the setting of the switching rod stops. See page 21, "Setting the Switching Rod Stops".

If the floor still does not operate correctly...

The floor hydraulic module may need servicing. Contact Halco to talk with a technical representative and to make service arrangements.

CLEANING

The floor must be cleaned regularly to prevent buildup of material which could cause the floor to operate inefficiently or bind. Areas affected may include, but are not limited to, between the deck slats, between the deck slats and sub-deck, between the deck slats and the forward wall, and between the deck and the exit door. The operator/owner should establish a cleaning cycle appropriate to the type of loads which are carried. The life of the floor will be maximized by regular cleaning.

INSPECTIONS

Inspect your floor regularly in order to monitor wear of your floor and to prevent further damage, if damage has already occurred. The following are some highlighted areas to inspect:

Deck Bolts: The 3/8" diameter deck bolts connecting the deck slats to the cross drives must be kept tight at all times! Loose deck bolts will damage your deck. The deck bolts must be checked after the first 5 to 10 loads. Torque from underneath to 35 ft-lbs [47 N-m].

In some cases 1/2" diameter deck bolts are installed. Torque 1/2" diameter deck bolts from underneath to 55 ft-lbs [75 N-m].

Decking: Inspect for wear or damage.

Bearings: Inspect for wear or damage.

Hydraulic Plumbing: Inspect the hydraulic system for leaks and abrasion wear. Maintain reservoir minimum/maximum levels.

Floor Structure: Inspect floor structure including hydraulic module mount and framework, hydraulic shafts, shaft-to-cross drive connections, cross drives, and sub-deck for damage and wear.

Hydraulic Module: Inspect the hydraulic module for leaks, loose mounting bolts, loose manifold bolts, worn wipers and seals, and pitted/worn/damaged shafts.

Sloped Sheet & Wiper: Make sure the sloped sheet is in good condition and that the wiper attached to the sloped sheet is keeping the gap between the forward wall and the end of the decking clear of material which could cause the floor to bind.

REPAIRS

Refer to the installation manual for repairs which extend beyond the scope of this owner's manual. Do not re-install defective components into your floor system. Contact Hallico for replacement components.

EXTERNAL PLUMBING

Refer to Figures 8 (page 14) or 9 (page 15) for plumbing details. Note that some hose lengths vary based on the floor width.

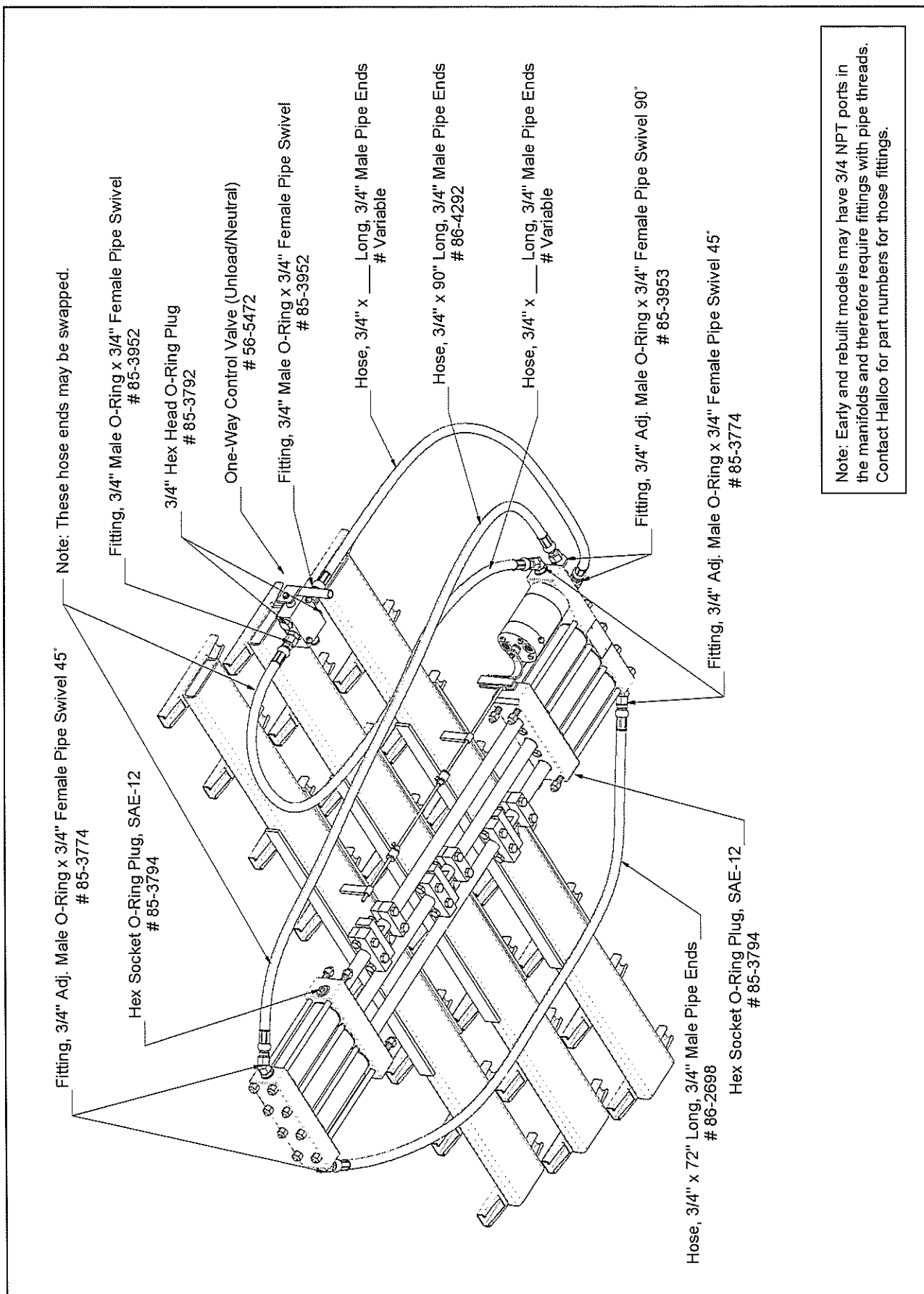

Note: These hose ends may be swapped.

Note: Early and rebuilt models may have 3/4 NPT ports in the manifolds and therefore require fittings with pipe threads. Contact Hallico for part numbers for those fittings.

-Figure 8-
Standard 4100 (One-Way) Plumbing

Fitting, 3/4" Adj. Male O-Ring x 3/4" Female Pipe Swivel 45°
85-3774

Fitting, 3/4" Male O-Ring x 3/4" Female Pipe Swivel
85-3952

Note: These hose ends may be swapped.

Hose, 3/4" x _____ Long, 3/4" Male Pipe Ends
Variable

Fitting, 3/4" Male O-Ring x 3/4" Female Pipe Swivel
85-3952

Two-Way Control Valve (Unload/Neutral/Load)
56-3632

Hose, 3/4" x _____ Long, 3/4" Male Pipe Ends
Variable

Hose, 3/4" x _____ Long, 3/4" Male Pipe Ends
Variable

Hose, 3/4" x 90° Long, 3/4" Male Pipe Ends
86-4292

Hose, 3/4" x _____ Long, 3/4" Male Pipe Ends
Variable

Hose, 3/4" x 72" Long, 3/4" Male Pipe Ends
86-2698

Fitting, 3/4" Adj. Male O-Ring x 3/4" Female Pipe 90°
85-3948

Fitting, 3/4" Male Pipe x 3/4" Female Pipe Swivel 90°
85-2662

Fitting, 3/4" Adj. Male O-Ring x 3/4" Female Pipe Swivel 90°
85-3953

Fitting, 3/4" Adj. Male O-Ring x 3/4" Female Pipe Swivel 45°
85-3774

Note: Early and rebuilt models may have 3/4 NPT ports in the manifolds and therefore require fittings with pipe threads. Contact Hallico for part numbers for those fittings.

-Figure 41-
Standard 4200 (Two-Way) Plumbing

HYDRAULIC MODULE OVERHAUL

**-Table 2-
Recommended Tools for Hydraulic Module Overhaul & Repairs**

Part Number	Description	Comment
93-4333	Head Manifold Installation Tool—2000, 3000, 4000, 6000 Series	Included in tool kit, P/N 93-4356
93-5413	Hydraulic Module Rebuild Fixture—2000, 4000 Series	For bench-top overhauls
53-3084	Piston Insertion Tool—2000, 4000 Series	Included in tool kit, P/N 93-4356
56-3712	Poppet Seating Tool—2000, 4000 Series	Included in tool kit, P/N 93-4356
85-2972	Pressure Gauge 0-5000 PSI	Included in tool kit, P/N 93-4356
93-4311	Rod Seal Insertion Tool	Included in tool kit, P/N 93-4356
93-4707	Tie Bolt Installation Tool, 5/8" Tie Bolts—2000, 4000 Series	For quick-driving the tie bolts

If the hydraulic module is accessible from below, it may be overhauled in-place. An advantage of overhauling the hydraulic module in-place is that when removing and torquing the piston nuts the shafts are kept from rotating by the cross drive clamps. No lifting of heavy assemblies is required, and the shafts are always kept in the same position and don't require realignment. Depending on shop equipment and the extent of the overhaul, it may be desirable to remove the entire hydraulic module and avoid working overhead from under the truck, trailer, or bin. Hydraulic modules may be shipped to Hallco for overhaul. Hallco recommends including the switching valve for testing.

Removing the Hydraulic Module

Refer to Figure 4 (page 6).

- Detach the hydraulic hoses from the hydraulic module & catch the hydraulic fluid drips in a drip pan (temporary port plugs recommended).
- Remove the switching rod.
- Remove the cross drive clamps.
- Support the weight of the hydraulic module.
- Remove the shaft bearing block assembly.
- Remove the anchor bolt nuts (by the mounting flange on the frame).
- Remove the anchor bolts far enough to clear the mounting flange.
- Lower the hydraulic module past the mounting flanges and cross members.
- Move the hydraulic module rearward to remove it.
- Drain the hydraulic fluid from the hydraulic module before disassembling or shipping it.

Disassembling the Hydraulic Module

Refer to Figure 4 (page 6), Figure 10 (page 18), and Table 3 (page 18).

Hallco recommends tagging or organizing the components as they are disassembled in such a way that they can be installed in their original positions. This will also help with inspecting for damage and wear (for example: score marks on a barrel ID may correlate with piston and seal damage as well).

- Remove the switching valve (refer to "Switching Valve Overhaul, page 22).
- Remove the tie and anchor bolts.
- Remove the base manifold.
- Remove the transfer tube & barrels.

- Remove the piston nuts and pistons. Note: The piston nuts were installed with 300 ft-lbs [407 N-m] of torque. The shafts will need to be held securely to keep them from rotating. Use the hydraulic module rebuild fixture, if rebuilding a removed hydraulic module. Shafts of hydraulic modules rebuilt in place are kept from rotating by the cross drive clamps.
- Remove the head manifold.
- Remaining seals may be removed from the head and base manifolds at this point.
- Poppet assemblies may be removed at any point.

Reassembling the Hydraulic Module

Hallco recommends replacing all hydraulic module seals when overhauling a hydraulic module. Prior to reassembly inspect the components for wear and damage. Do not reassemble defective components.

- Replace the seals (lubricate with hydraulic fluid) in the head and base manifolds and on the pistons as shown in Figures 10 (page 18) & 12 (page 20). Use the shaft seal insertion tool listed in the recommended tools list, Table 2 (page 16), to insert the shafts seals.
- Install the poppet assemblies in the manifolds, if applicable.
- Assemble the head manifold onto the shafts.
- Insert the pistons (with seals) into the barrels. Use the piston insertion tool listed in the recommended tools list, Table 2 (page 16), to insert the pistons into the barrels.
- Install barrel seals on the barrel ends (Do not place the barrel seals in the manifold. They are prone to getting pinched when the barrels are pressed in.), then install the pistons onto the shafts (pistons inside barrels). Note: The orientation of the pistons is important when installing them on the shafts (see Figure 12, page 20), however the barrels are symmetrical.
- Secure the pistons with the 1" NF stover nuts. Torque the nuts to 300 ft-lbs [407 N-m].
- Install the transfer tube (verify that corresponding o-rings are already installed).
- Install the base manifold.
- Install the tie bolts and corresponding lock nuts. Make sure the tie bolts thread into the head manifold at least 1" [25 mm]. Snug up the lock nuts; do not torque at this time. These will be torqued when the hydraulic module is installed (if removed entirely) or when this end of the hydraulic module overhaul is complete (if the hydraulic module was never removed).
- Loosely assemble the anchor bolts and lock nuts at this time or set them aside until the hydraulic module is attached to the drive unit frame.

Installing the Hydraulic Module

- Install the hydraulic module into position in the reverse order of the way it was removed.
- Secure it in position with the anchor bolts and lock nuts. Snug up the lock nuts.
- Tighten the nuts on the tie and anchor bolts using a criss-cross pattern. See Figure 11 (page 19). Tighten the bolts evenly so that the manifolds remain parallel as they are pressed towards each other. Torque to 60 ft-lbs [81 N-m] on the first pass. Finish with a second pass using the same criss-cross pattern. Torque to 120 ft-lbs [163 N-m].

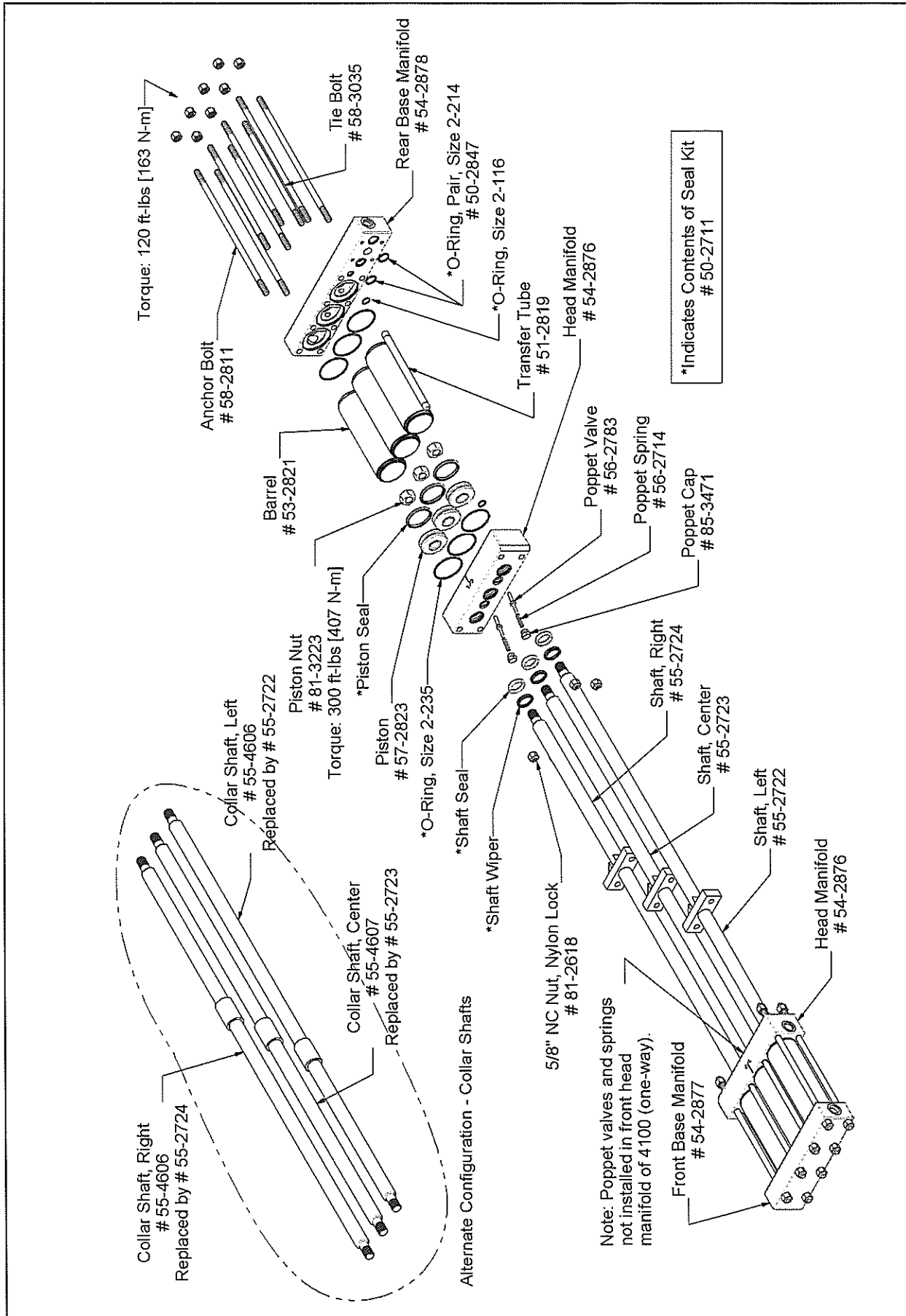

-Figure 10-
 4000 Series Hydraulic Module--Exploded View

**-Table 3-
Parts List 4100 & 4200 Series Hydraulic Modules**

Qty for 4100	Qty for 4200	P/N	Description
8	8	58-2811	Anchor Bolt - 5/8" x 18.3/4"
6	6	53-2821	Barrel - 4000 Series - 10" Stroke (3" ID x 11")
1	1	54-2877	Base Manifold, Front
1	1	54-2878	Base Manifold, Rear
2	2	54-2876	Head Manifold
24	24	81-2618	Nut, Nylon Lock - 5/8" NC
6	6	57-2823	Piston - 3" OD
6	6	81-3223	Piston Nut, 1" NF Stover Nut
4*	4	56-2716	Poppet Valve Assembly
2*	4	56-2783	-- Poppet Valve
4*	4	85-3471	-- Poppet Valve Cap
2*	4	56-2714	-- Poppet Valve Spring
1	1	50-2711	Seal Kit - 4000 Series
1	1	55-2722	Shaft Left (Driver) Side - (Block Style)
1	1	55-2723	Shaft Center - (Block Style)
1	1	55-2724	Shaft Right (Passenger) Side - (Block Style)
8	8	58-3035	Tie Bolt - 5/8" x 15.1/2"
2	2	51-2819	Transfer Tube - 3000, 4000, 6000 Series - 10" Stroke

*The 4100 (one-way) hydraulic module does not have poppet valves or springs in the forward head manifold. Only install poppet caps.

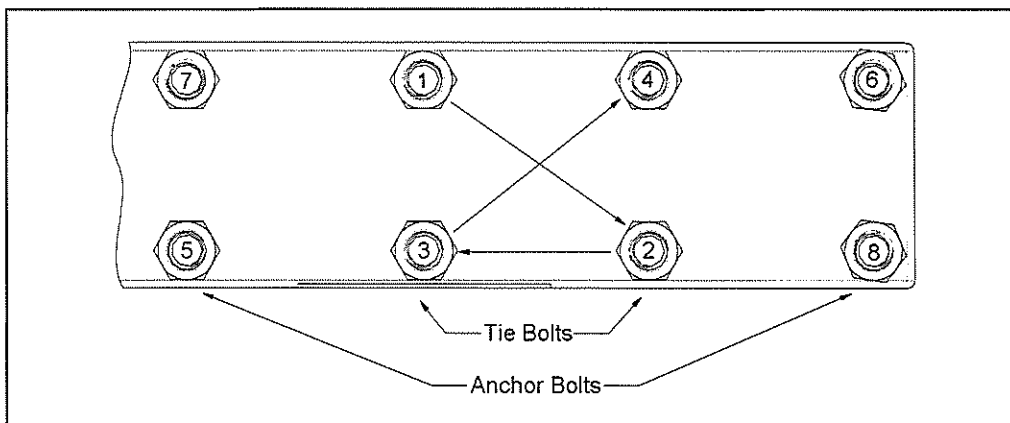

**-Figure 11-
Manifold Torque Pattern**

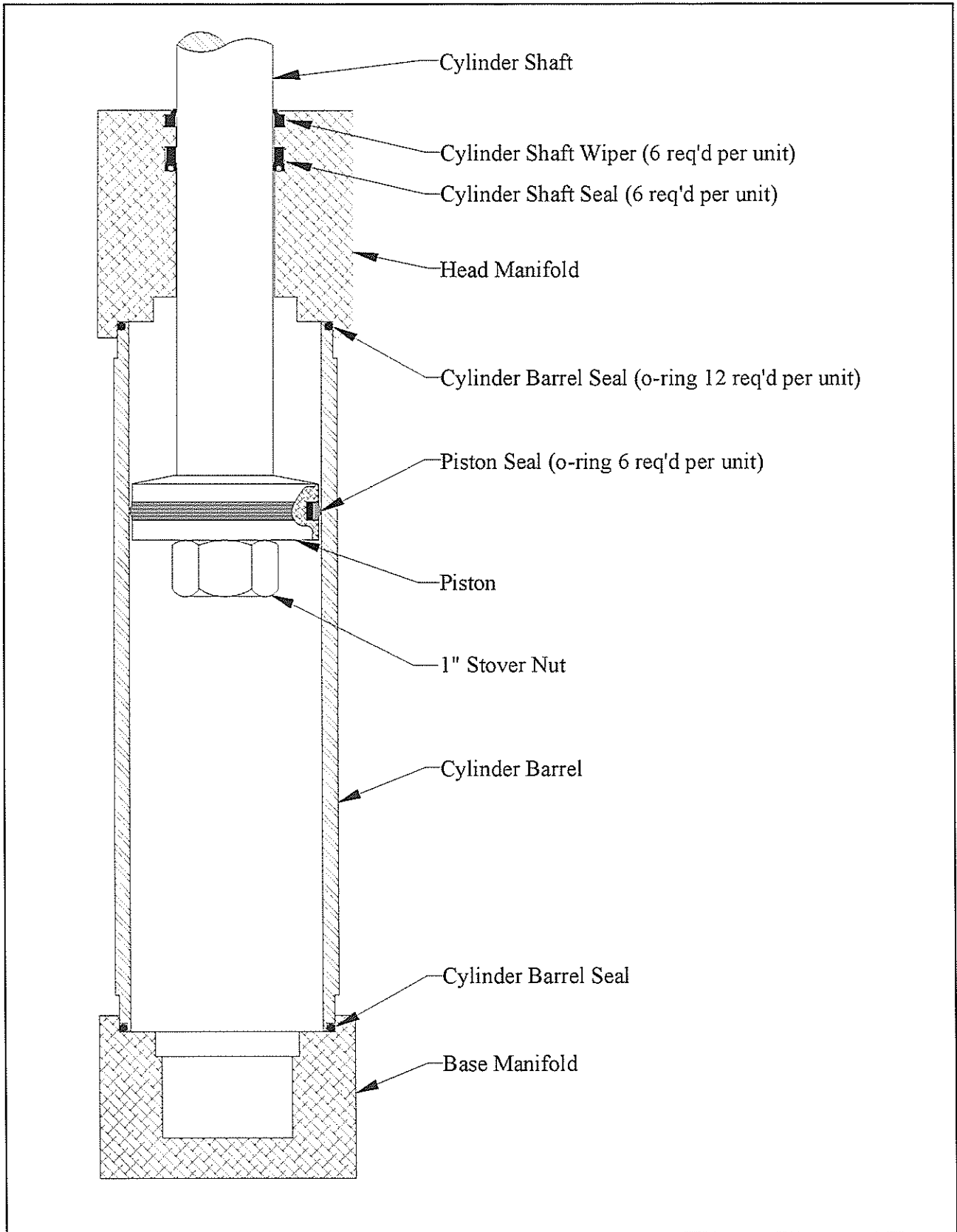

-Figure 12-
Seal Installation

SETTING THE SWITCHING ROD STOPS

1. Release and move stops "A" and "B" away from the front and rear triggers.
2. Move the switching rod rearward toward the switching valve until it stops.
3. Apply hydraulic pressure (load or unload mode) until the shafts are fully extended forward away from the switching valve, then shut off pressure.
4. Move the switching rod away from the switching valve until it stops. Move and set stop "A" firmly against the rear trigger.
5. Apply hydraulic pressure until the shafts are fully retracted rearward towards the switching valve, then shut off pressure.
6. Move the switching rod rearward toward the switching valve until it stops. Move and set stop "B" firmly against the front trigger.
7. Mark the positions of stops "A" and "B" on the switching rod.
8. Apply hydraulic pressure to the cylinders until the triggers are free from the stops by at least $\frac{3}{8}$ ". Shut off the pressure. Move stop "A" $\frac{3}{8}$ " [10 mm] toward the rear trigger and tighten firmly. Move stop "B" $\frac{3}{8}$ " [10 mm] toward the front trigger and tighten firmly.

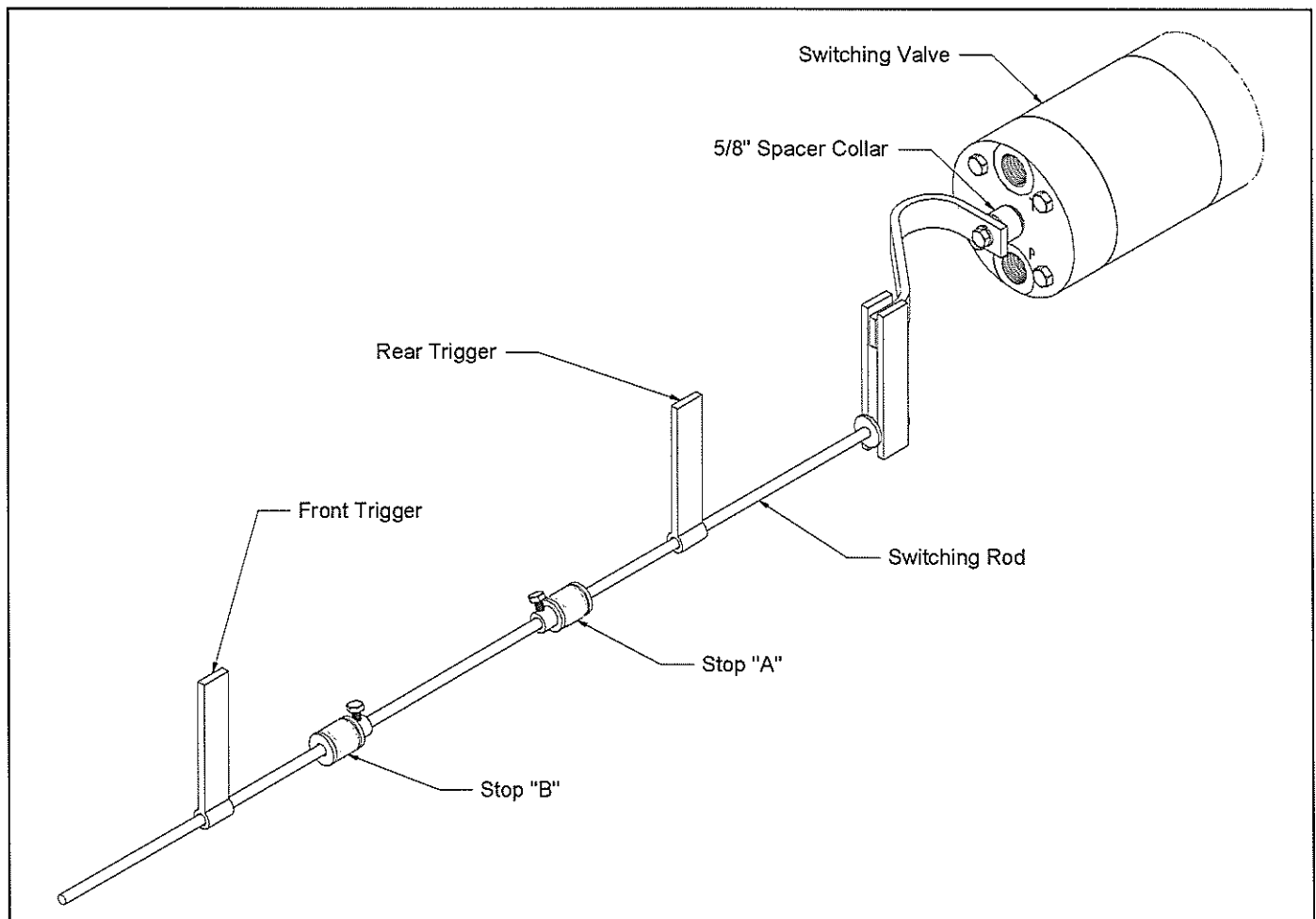

-Figure 13-
Switching Rod Stops

SWITCHING VALVE OVERHAUL

The switching valve can be overhauled to correct seal leakage only — not bypass. If any of the major components require replacement, the entire valve will need to be replaced.

If bypass is suspected because of overheating of the switching valve during operation, send the switching valve to Hallco for testing or replace entirely.

Refer to Figure 4 (page 6) and 14 (page 23).

Removing the Switching Valve

- Disconnect the switching rod mechanism.
- Remove the switching valve stop bolt, washer and collar.
- Remove the switching valve mount bolts.

Disassembling the Switching Valve

- Remove the cap screws which attach the end caps to the valve body.
- Slide the end caps away from the valve body.
- Remove the pilot rod and the spool.
- Remove the o-rings and shaft wipers.

Inspecting the Switching Valve Components

- Inspect the spool, pilot rod, spool bore, and pilot rod bores for scoring and burrs.
- Inspect all the remaining seal areas. The seal areas must be smooth and free of scoring and burrs.
- Inspect the fasteners and threaded holes for good thread engagement.

Reassembly of the Switching Valve

Hallco recommends replacing all the switching valve seals when overhauling the switching valve.

- Lubricate the shaft wipers and o-rings with hydraulic fluid and install them in the end caps.
- Lubricate the valve spool and pilot rod with hydraulic fluid and insert the spool into the valve body and the pilot rod into the spool. Center them on the valve body.
- Place the o-rings which go between one of the end caps and the body in their respective seal grooves and slide on the end cap. Note the location of the alignment pin. Repeat for the other end cap.
- Install the cap screws which hold the forward end cap on, snug them up, then torque them to 30 ft-lbs [41 N-m]. Use two of the same size cap screws to hold the rear end cap snug until it is ready to be installed on the hydraulic module.

Installing the Switching Valve

- Install the switching valve onto the hydraulic module. Note that port "P" goes below port "T", and the 1/4" NPT Plug is on the underside of the switching valve. Torque the mount bolts to 30 ft-lbs [41 N-m].
- Reinstall the switching valve stop bolt, washer and collar.
- Reattach the switching rod mechanism making sure to include the switching rod stops (collars, rubber bumpers, washers).

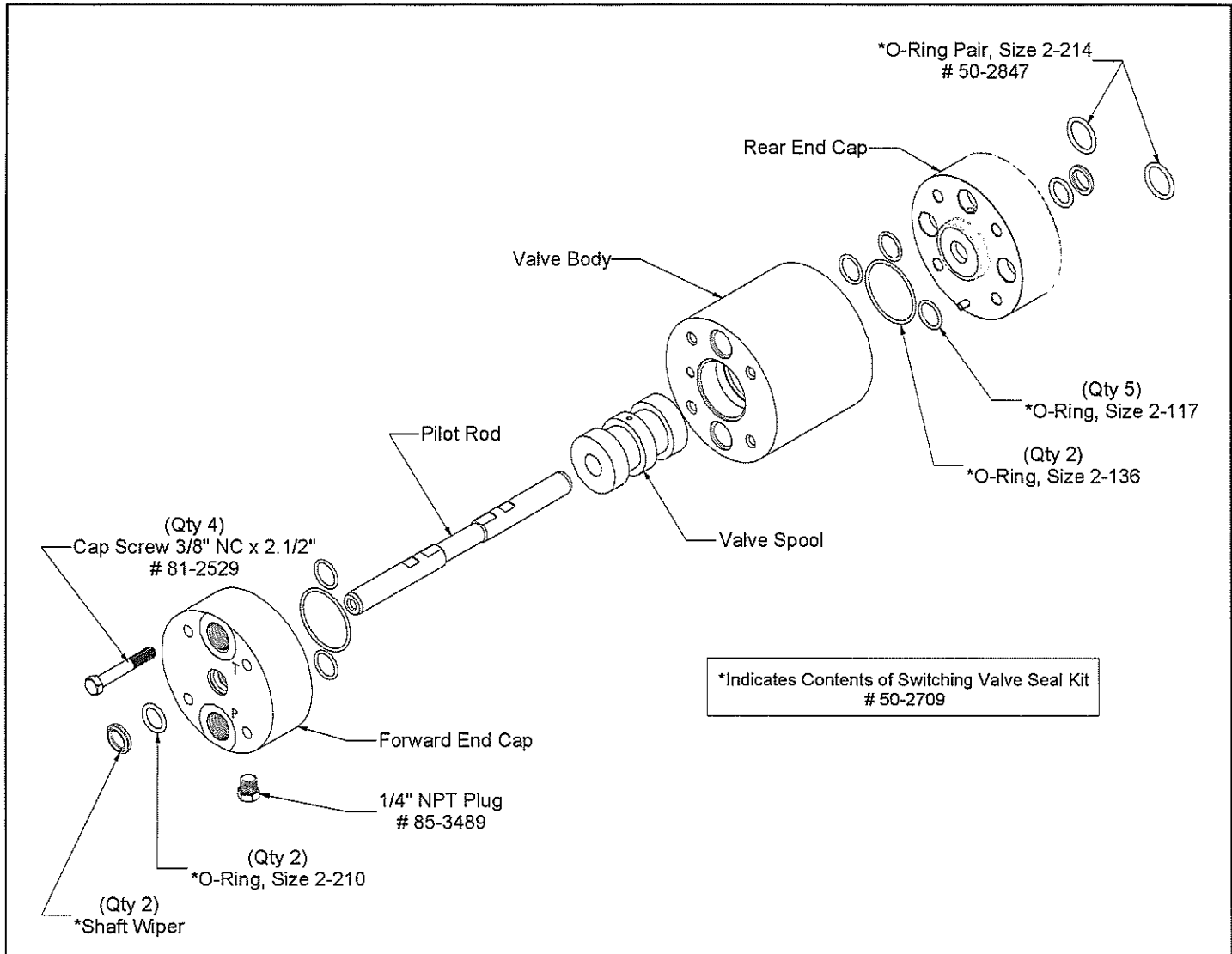

-Figure 14-
Switching Valve--Exploded View

CONTROL VALVE OVERHAUL

The control valve can be overhauled to correct external leakage only. If the valve has excessive internal bypass, it will need to be replaced entirely.

Refer to Figure 15 (this page) or 16 (page 25).

Disassembling the Control Valve

- Remove the cap screw and lock washer which attach the valve handle to the spool. Note: If the spool turns so that the screw cannot be removed, hold the end of the spool at the opposite end beyond the retaining ring with locking pliers or similar. Do not grip the area which slides in the valve body.
- Remove the spacer collar (one-way only).
- Remove the spool by sliding it toward the retaining ring side. Note that the retaining ring does not have to be removed.
- Remove the two o-rings from the valve body.

Reassembling the Control Valve

Prior to reassembly inspect all components for wear and damage. Do not reinstall defective components.

- Replace the two o-rings in the valve body with new o-rings. Lubricate the o-rings with hydraulic fluid before installing them.
- Install the retaining ring on the spool, if it was removed.
- Lubricate the spool with hydraulic fluid and insert it into the valve body.
- Attach the valve handle with the cap screw and lock washer.

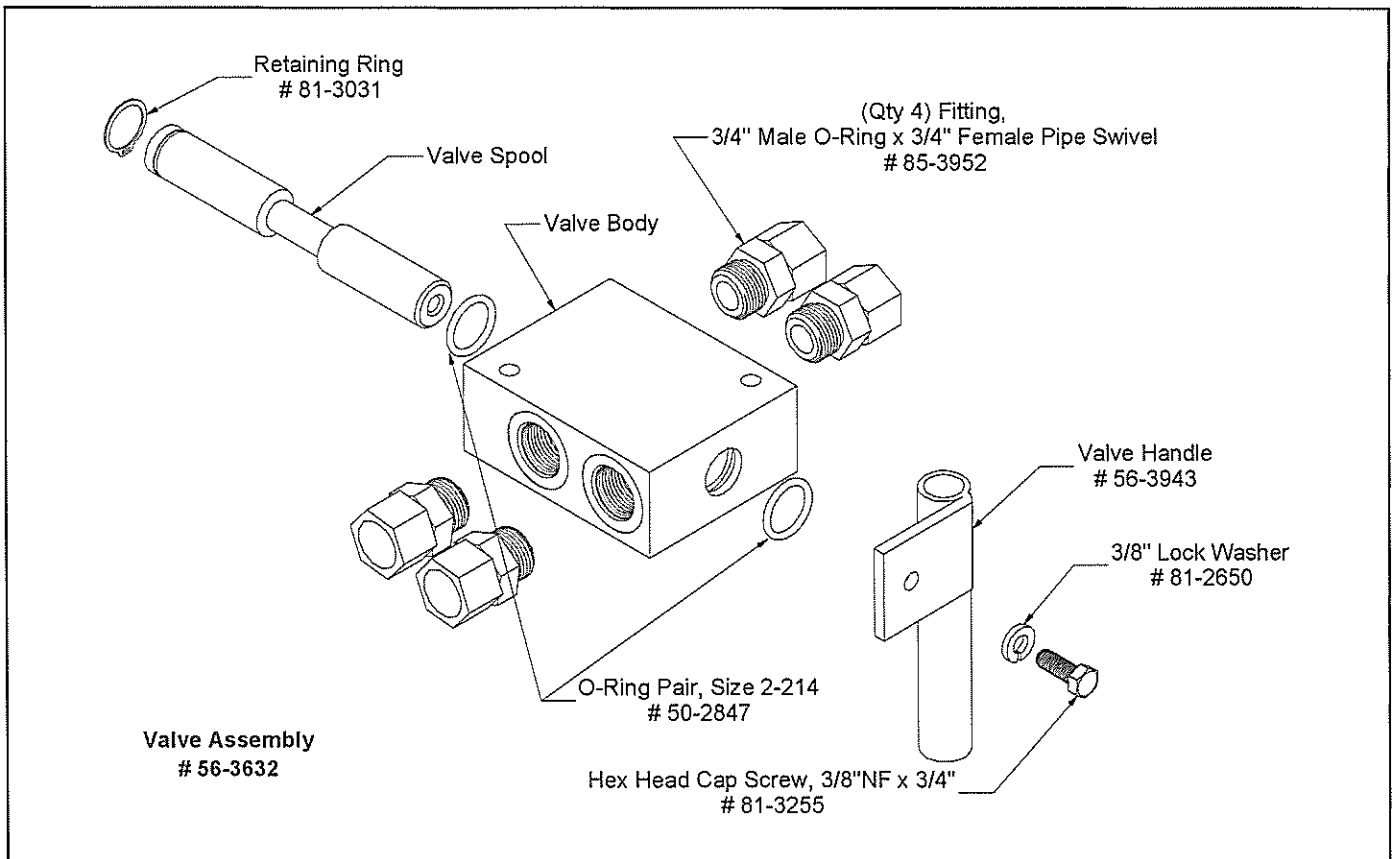

-Figure 15-
Standard Control Valve, Two-Way--Exploded View

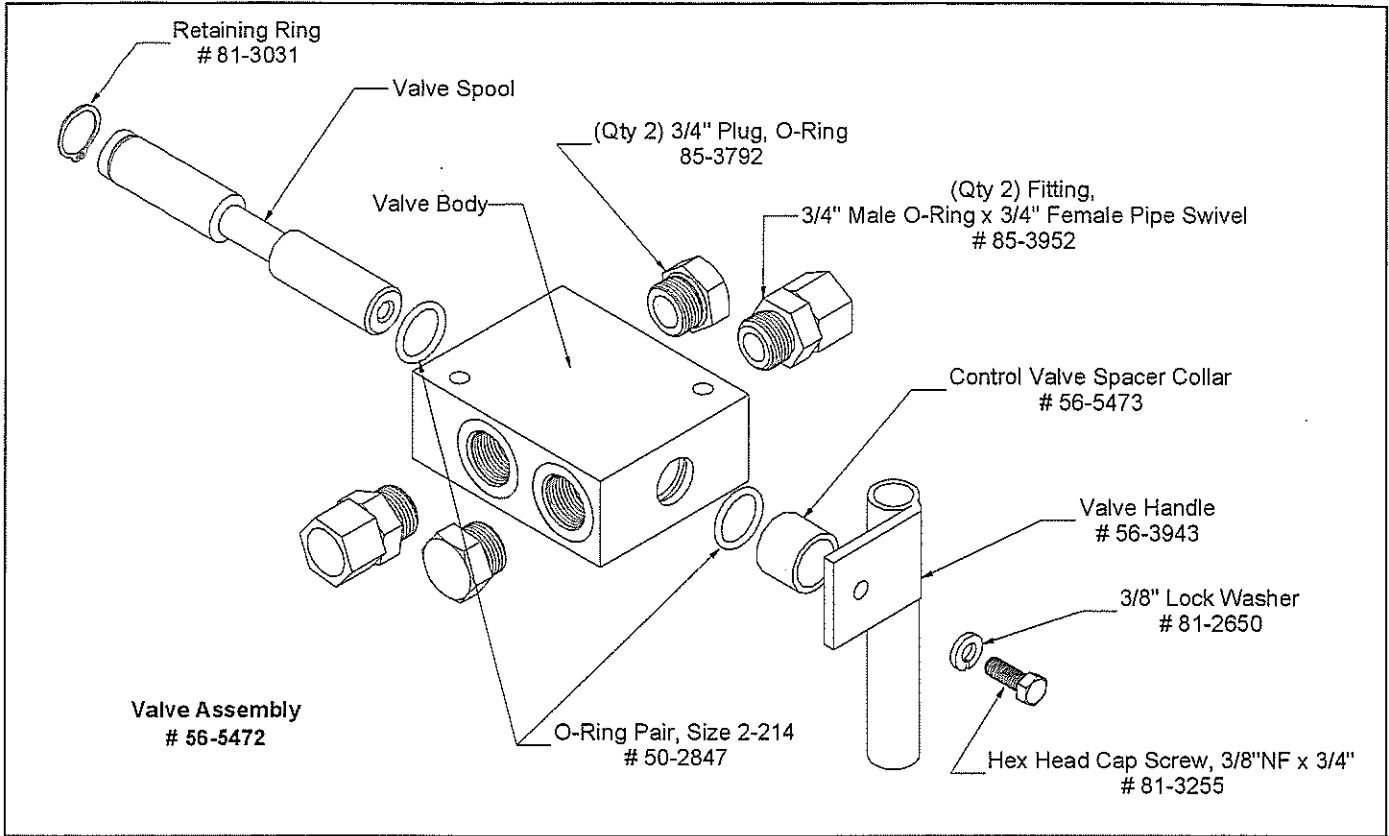

-Figure 16-
Standard Control Valve, One-Way--Exploded View

